

THE INFORMATION CONTAINED IN THIS DRAWING IS THE SOLE PROPERTY OF L-COM, INC. ANY REPRODUCTION IN PART OR WHOLE WITHOUT THE WRITTEN PERMISSION OF L-COM, INC. IS PROHIBITED.

REVISIONS			
REV	DESCRIPTION	DATE	APPROVED
A	INITIAL RELEASE	09/11/2020	MBLACKWOOD

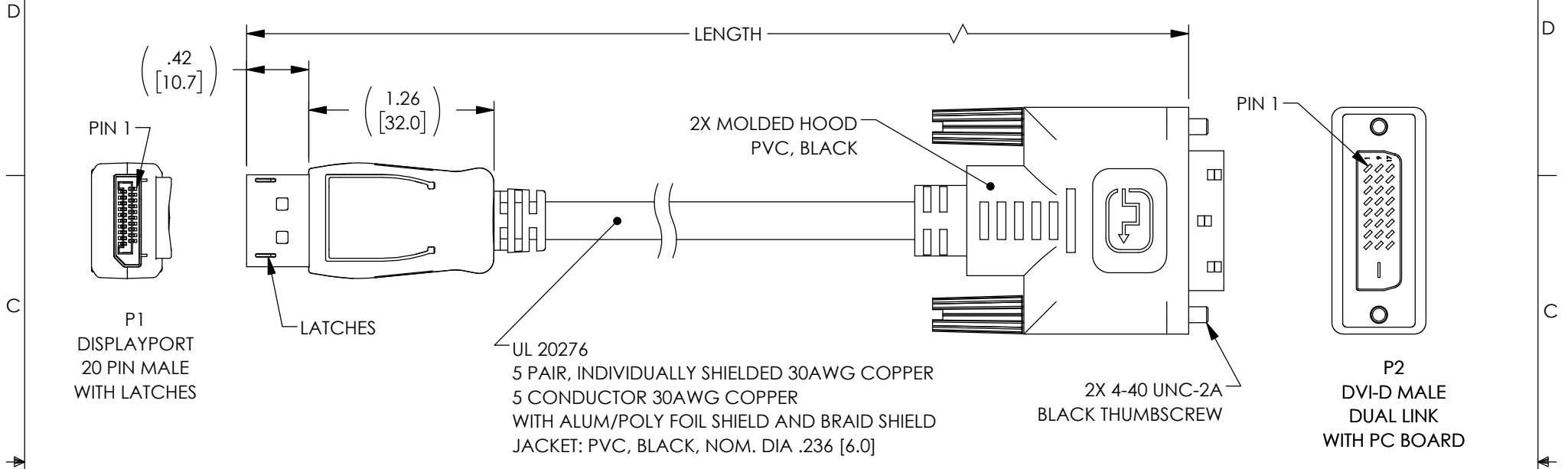

PART NUMBER	LENGTH(mm)
VPA00004-1M	1000.0 ±30.0
VPA00004-3M	3000.0 ±80.0

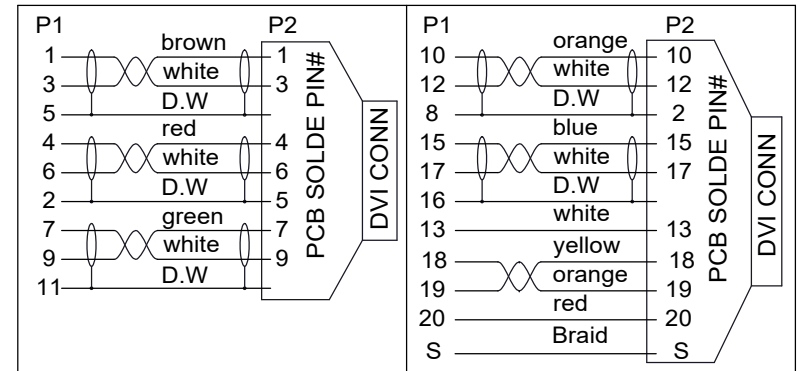

NOTES:

- DUST CAPS INSTALLED PRIOR TO SHIPPING (NOT SHOWN)
- ELECTRICAL TEST:100% DP TO DVI 1080P TEST
 - SIGNAL SOURCE RESOLUTION UXGA: 1920*1080P.
 - FREQUENCY: 60HZ.
 - THERE IS NO SIGNAL JITTER AND DRAGGING IN THE VIDEO GHOST, LACK OF COLOR AND OTHER ABNORMAL DISPLAY
 - AUDIO NO NOISE, SOUND CLEAR.
- PACKAGE:
COMPONENT SHALL BE PACKAGED IN ACCORDANC: WITH A LSP-010-2 LABEL ON THE BAG.
- INSIDE THE MOLDED P2 END MUST USE COPPER FOIL AND SOLDER THE BRAID 360 DEGREE TO THE SHELL .

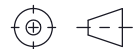
UNLESS OTHERWISE SPECIFIED, DIMENSIONS ARE IN INCHES [mm] OVERALL CABLE LENGTH TOLERANCE: ≤12 [305] = +1 [25] / -0 >12 [305] ≤60 [1524] = +2 [51] / -0 >60 [1524] ≤120 [3048] = +4 [102] / -0 >120 [3048] ≤300 [7620] = +6 [152] / -0 >300 [7620] = +5% / -0 ALL OTHER DIMENSIONAL TOLERANCES: .X = ± .2 [5] FRACTIONS ± 1/32 .XX = ± .02 [.5] ANGLES ± 1° .XXX = ± .005 [.13]	APPROVALS DRAWN BY MVEERAPPAN CHECKED BY DFRISIELLO APPROVED BY MBLACKWOOD	DATE 08/23/2020 09/11/2020 09/11/2020	 an INFINITO brand	50 High Street, West Mill, North Andover, MA 01845 USA. Phone: 1.800.341.5266 1.978.682.6936		
	CONFIGURATION DETAILS OF UNDIMENSIONED FEATURES MAY VARY COLOR VARIATIONS MAY OCCUR	CATEGORY VIDEO	PRODUCT DESCRIPTION DP to DVI	SIZE A	CAGE CODE 43321	ITEM NO. VPA00004
THIRD-ANGLE PROJECTION 	SCALE: NONE	CAD FILE: VPA00004.SLDDRW	SHEET 1 OF 1			