

THE INFORMATION CONTAINED IN THIS DRAWING IS THE SOLE PROPERTY OF L-COM, INC. ANY REPRODUCTION IN PART OR WHOLE WITHOUT THE WRITTEN PERMISSION OF L-COM, INC. IS PROHIBITED.

REVISIONS			
REV	DESCRIPTION	DATE	APPROVED
A	INITIAL RELEASE	8/16/11	D.GRIFFIN
B	ECN 5688: ADDED GASKET AND NUT	8/25/11	D.FRISIELLO

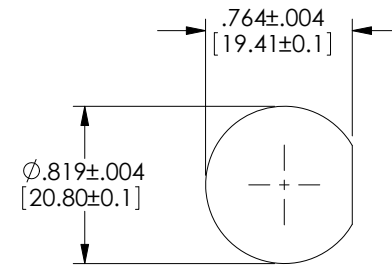

RECOMMENDED
PANEL OPENING

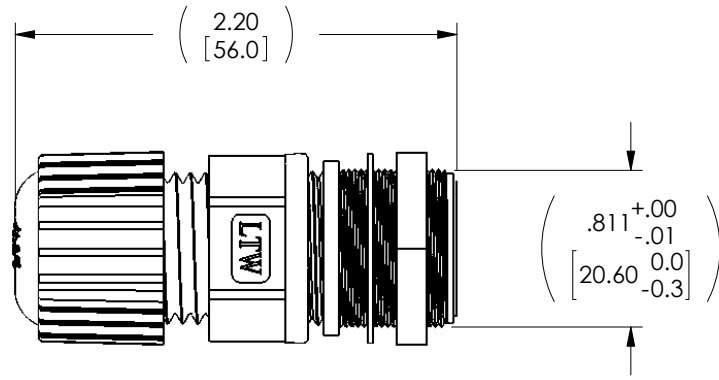
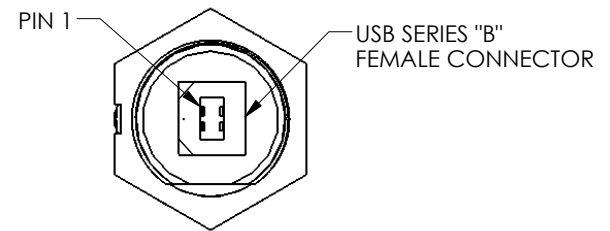
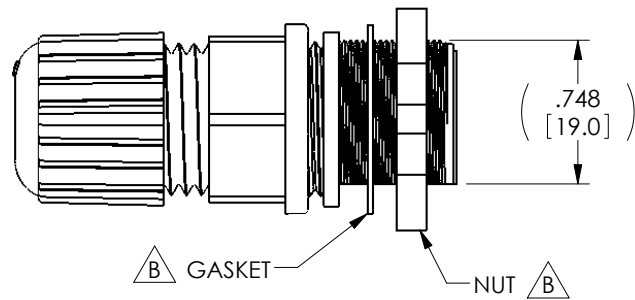

NOTES:

CONNECTOR: BLACK, USB SCREW TYPE.
 BACK SHELL: BLACK NYLON.
 JACK: BLACK, PBT, GOLD 30µ
 GASKET: BLACK, EPDM.
 CLAMP RING: BLACK, NYLON.
 SEALING NUT: BLACK, NYLON.
 NUT: BLACK, NYLON.

COMPONENT SHALL BE INDIVIDUALLY PACKAGED IN ACCORDANCE WITH L-COM SPEC. PS-0031.

RoHS Compliant ✓

UNLESS OTHERWISE SPECIFIED, DIMENSIONS ARE IN INCHES [mm] OVERALL CABLE LENGTH TOLERANCE: ≤12 [305] = +1 [25] / -0 >12 [305] ≤60 [1524] = +2 [51] / -0 >60 [1524] ≤120 [3048] = +4 [102] / -0 >120 [3048] ≤300 [7620] = +6 [152] / -0 >300 [7620] = +3% / -0% ALL OTHER DIMENSIONAL TOLERANCES: .X = ± .2 .XX = ± .02 .XXX = ±.005	APPROVALS D. CASTRO CHECKED BY D. PARHAM APPROVED BY S. SMITH	DATE 8/16/11 8/16/11 8/16/11	45 BEECHWOOD DRIVE NORTH ANDOVER, MA 01845
	CONFIGURATION DETAILS OF UNDIMENSIONED FEATURES MAY VARY		
PROJECTION 	COLOR VARIATIONS MAY OCCUR	SIZE A	FSCM NO. 43321
DWG. NO. WPUSBCN-B-2.0		REV. B	SCALE: NONE CAD FILE: WPUSBCN-B-2.0.SLDDRW SHEET 1 OF 2

THE INFORMATION CONTAINED IN THIS DRAWING IS THE SOLE PROPERTY OF L-COM, INC. ANY REPRODUCTION IN PART OR WHOLE WITHOUT THE WRITTEN PERMISSION OF L-COM, INC. IS PROHIBITED.

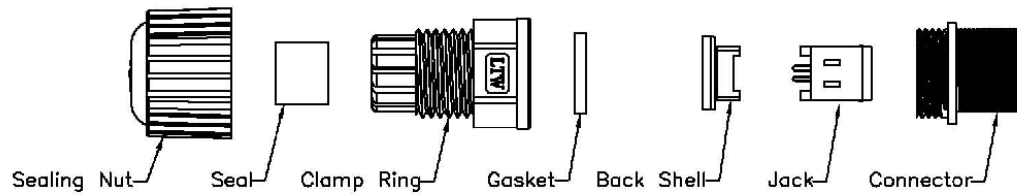
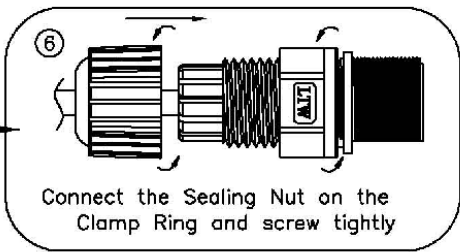
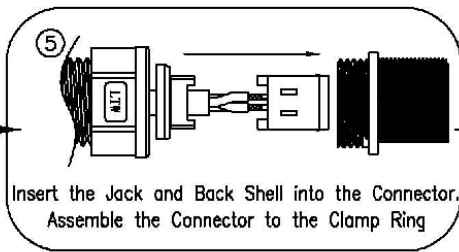
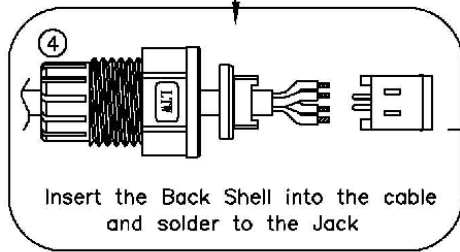
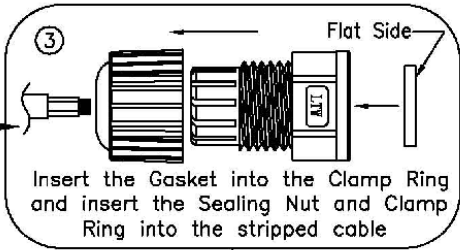
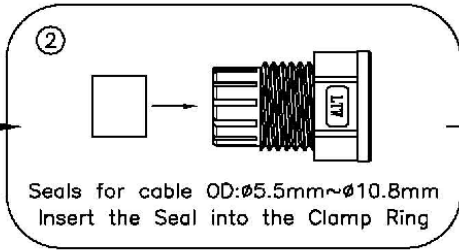
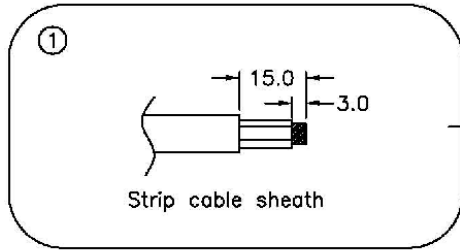

L-com Global Connectivity		45 BEECHWOOD DRIVE NORTH ANDOVER, MA 01845	
CATEGORY		USB	
PRODUCT DESCRIPTION		CONN, WTR PRF USB-B-F	
SIZE A	FSCM NO. 43321	DWG. NO. WPUSBCN-B-2.0	REV. B
SCALE: NONE CAD FILE: WPUSBCN-B-2.0.SLDDRW			SHEET 2 OF 2