

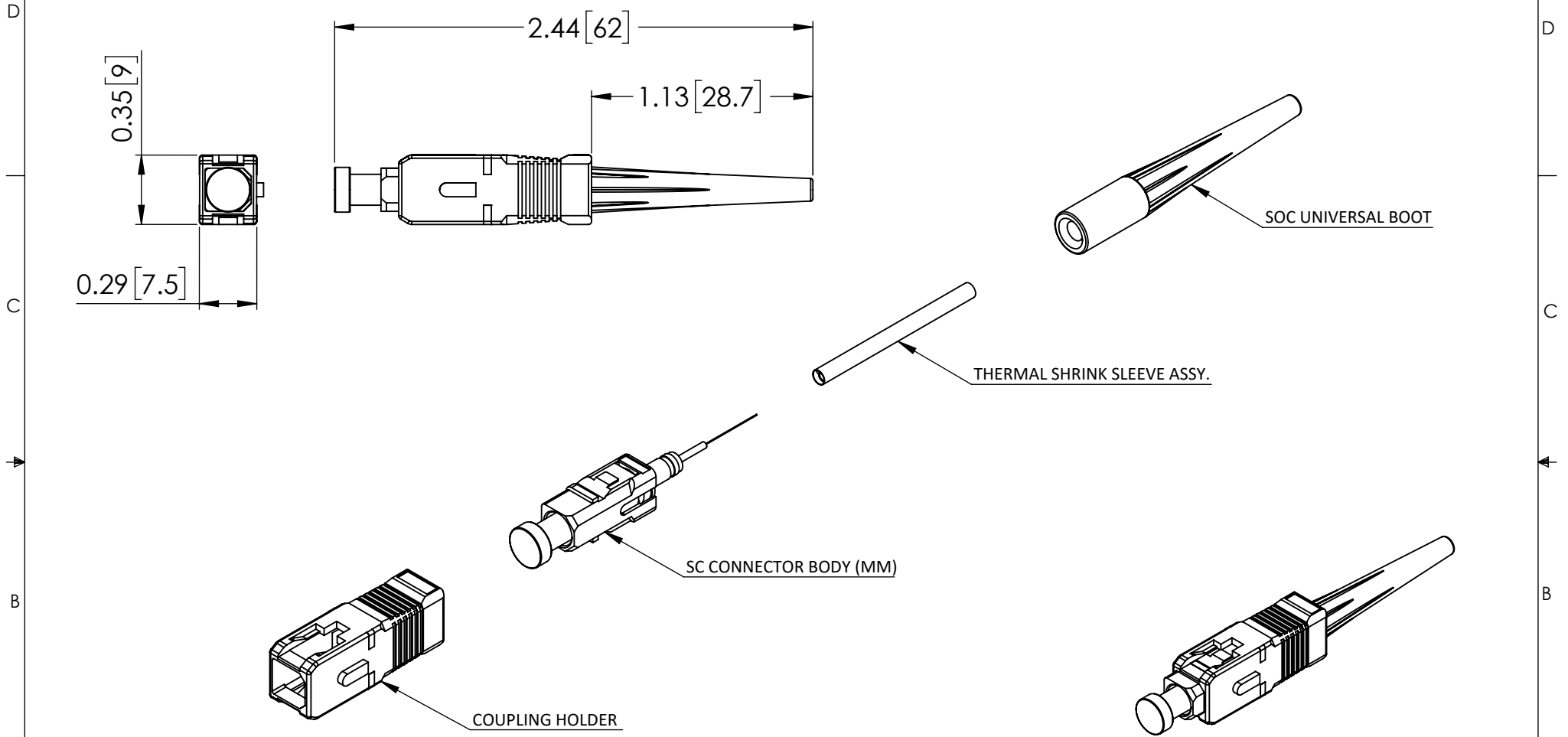

THE INFORMATION CONTAINED IN THIS DRAWING IS THE SOLE PROPERTY OF L-COM, INC. ANY REPRODUCTION IN PART OR WHOLE WITHOUT THE WRITTEN PERMISSION OF L-COM, INC. IS PROHIBITED.

REVISIONS			
REV	DESCRIPTION	DATE	APPROVED
A	INITIAL RELEASE	04/13/22	PHOSPODAR



NOTES:

1. ALL DIMENSIONS ARE REFERENCE ONLY.
2. CONNECTORS ACCOMPANIED WITH A SC SOC DUST CAP WITH EXTENDED HANDLEBAR INSTALLED (NOT SHOWN).
3. PACKAGE CONSIST OF 10 UNITS, INDIVIDUALLY KITTED. PRODUCT SHALL BE PACKAGED IN ACCORDANCE WITH L-COM SPECIFICATION PS-0031.

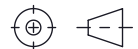
UNLESS OTHERWISE SPECIFIED, DIMENSIONS ARE IN INCHES [mm] OVERALL CABLE LENGTH TOLERANCE: ≤12 [305] = +1 [25] / -0 >12 [305] ≤60 [1524] = +2 [51] / -0 >60 [1524] ≤120 [3048] = +4 [102] / -0 >120 [3048] ≤300 [7620] = +6 [152] / -0 >300 [7620] = +5% / -0 ALL OTHER DIMENSIONAL TOLERANCES: .X = ± .2 [5] FRACTIONS ± 1/32 .XX = ± .02 [5] ANGLES ± 1° .XXX = ± .005 [1.3]	APPROVALS	DATE	 50 High Street, West Mill, North Andover, MA 01845 USA. Phone: 1.800.341.5266 1.978.682.6936
	DRAWN BY VTHANGARAJ CHECKED BY PHOSPODAR APPROVED BY PHOSPODAR	04/13/22 04/13/22 04/13/22	
THIRD-ANGLE PROJECTION 	CONFIGURATION DETAILS OF UNDIMENSIONED FEATURES MAY VARY COLOR VARIATIONS MAY OCCUR	PRODUCT DESCRIPTION SC MM SOC 0.9mm OM3 Aqua.	SCALE: NONE CAD FILE: SOC-SC-M3-09AQ-10PK.SLDDRW SHEET 1 OF 1
SIZE A	CAGE CODE 43321	ITEM NO. SOC-SC-M3-09AQ-10PK	REV. A