

THE INFORMATION CONTAINED IN THIS DRAWING IS THE SOLE PROPERTY OF L-COM, INC. ANY REPRODUCTION IN PART OR WHOLE WITHOUT THE WRITTEN PERMISSION OF L-COM, INC. IS PROHIBITED.

REVISIONS			
REV	DESCRIPTION	DATE	APPROVED
A	INITIAL RELEASE	1/14/13	D.GRIFFIN

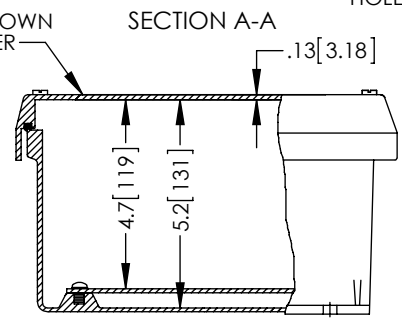
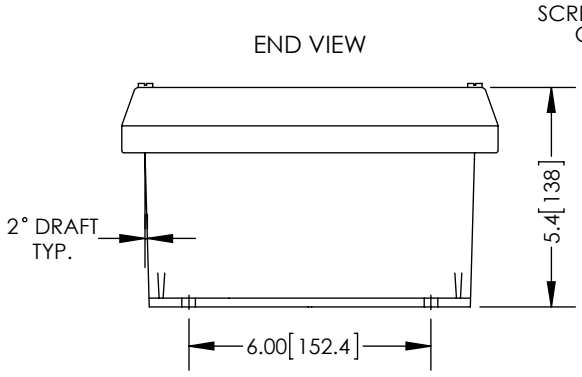
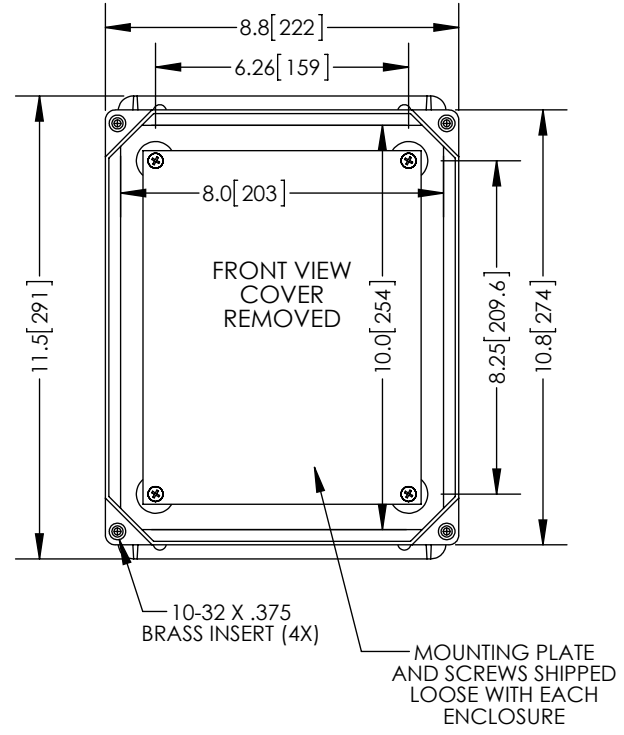
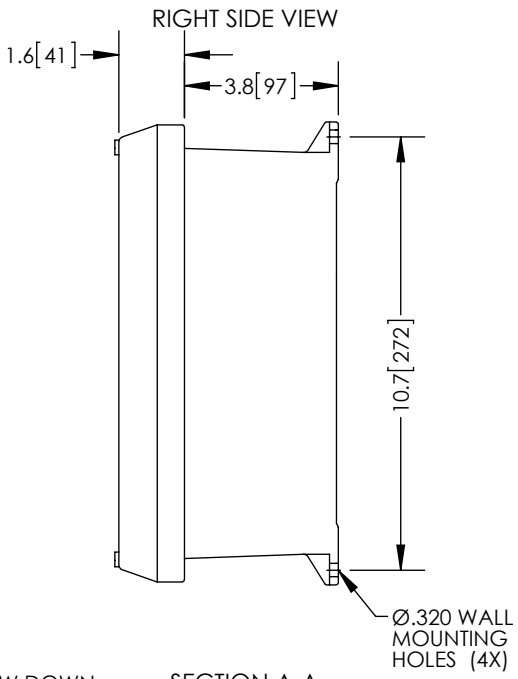
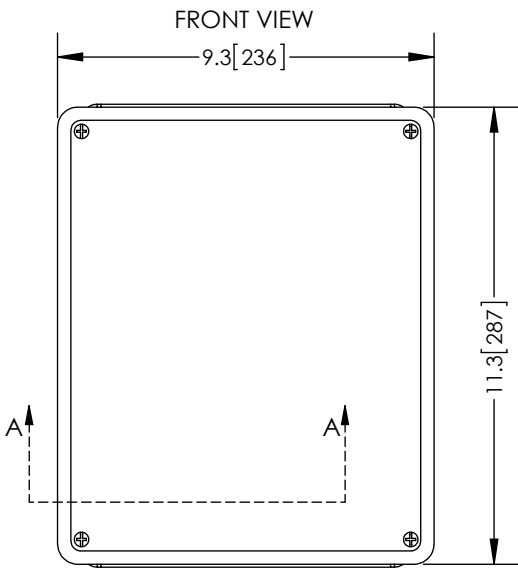

- NOTE:
- ENCLOSURE MATERIAL-GRAY (RAL7035)
HOT MOLDED FIBERGLASS REINFORCED POLYESTER
 - NEMA RATED TYPE 3, 3R, 3S, 4, 4X, 12 AND 13 PRIOR TO MODIFICATIONS.
 - IEC 529 RATED IP 66 PRIOR TO MODIFICATION.
 - TEMPERATURE RANGE FROM -50 DEG C TO 150 DEG C.
 - SELF EXTINGUISHING AND HALOGEN FREE.
 - CABINETS ARE MAINTENANCE FREE AND CORROSION RESISTANT.
 - SHALL BE PACKAGED AS PER L-COM SPEC PKG-00070
 - ALL DIMENSIONS FOR REFERENCE ONLY

RoHS Compliant ✓

UNLESS OTHERWISE SPECIFIED, DIMENSIONS ARE IN INCHES [mm] DIMENSIONAL TOLERANCES: .X = ±.1 .XX = ±.01 .XXX = ±.005 ANGULAR TOLERANCES: ALL = ± 1° PROJECTION 	APPROVALS	DATE		45 BEECHWOOD DRIVE NORTH ANDOVER, MA 01845	
	DRAWN BY B.PUCHASKI	01/11/13			
	CHECKED BY P.PESA	01/11/13	CATEGORY	ENCLOSURE	
	APPROVED BY P.PESA	01/11/13	PRODUCT DESCRIPTION	FRP NEMA ENCLOSURE - 10 X 8 X 5 SCREW COVER AND ALUMINUM MNT PLATE	
	COLOR VARIATIONS MAY OCCUR	SIZE A	FSCM NO. 43321	DWG. NO. NBC100805-KIT	REV. A
		SCALE: NONE	CAD FILE: NBC100805-KIT.SLDDRW		SHEET 1 OF 1