

THE INFORMATION CONTAINED IN THIS DRAWING IS THE SOLE PROPERTY OF L-COM, INC. ANY REPRODUCTION IN PART OR WHOLE WITHOUT THE WRITTEN PERMISSION OF L-COM, INC. IS PROHIBITED.

REVISIONS			
REV	DESCRIPTION	DATE	APPROVED
A	INITIAL RELEASE	04/04/2013	BPUCHASKI
B	ECN 9485 UPDATED PCB OUTLINE LOCATION	10/29/2018	BPUCHASKI

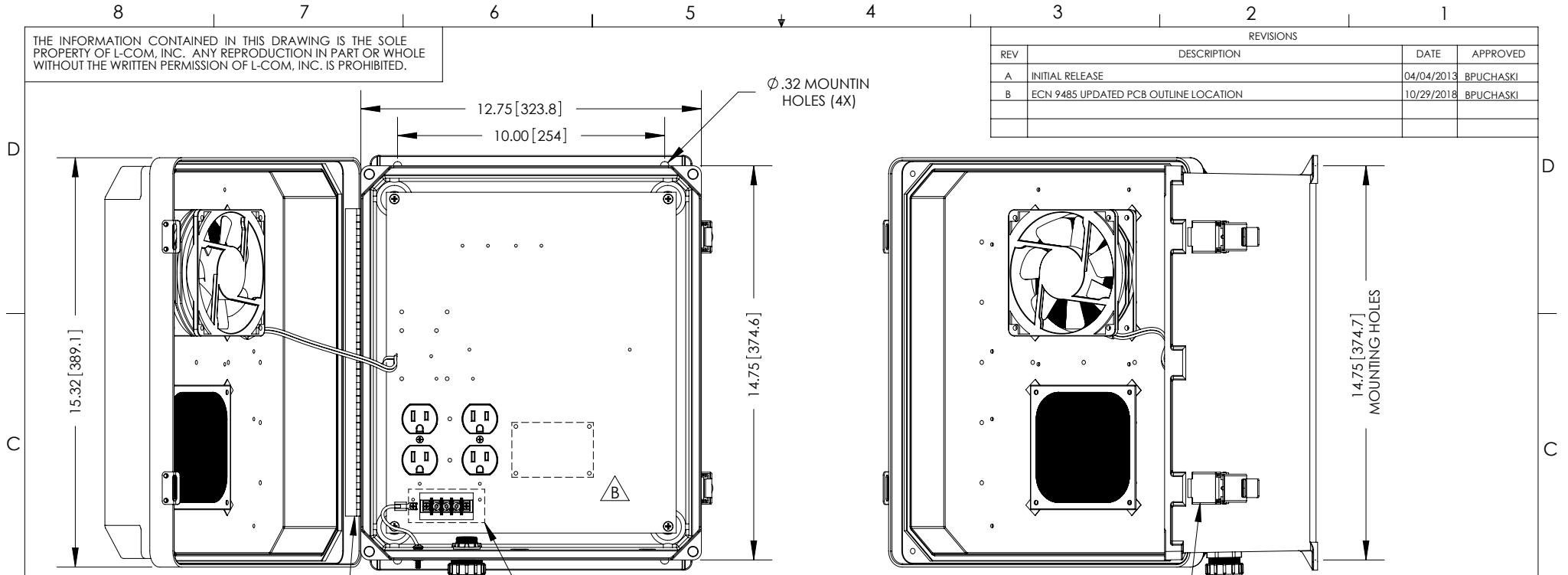

HIDDEN LINES REPRESENT COMPONENTS ON BACK OF PLATE --DO NOT DRILL--

- NOTE:**
- ENCLOSURE MATERIAL-GRAY (RAL7035) HOT MOLDED FIBERGLASS REINFORCED POLYESTER
 - NEMA RATED TYPE 3, 3R, 3S, 4, 4X, 12 AND 13 PRIOR TO MODIFICATIONS.
 - IEC 529 RATED IP 66 PRIOR TO MODIFICATION.
 - TEMPERATURE RANGE FROM -50 DEG C TO 150 DEG C.
 - SELF EXTINGUISHING AND HALOGEN FREE.
 - CABINETS ARE MAINTENANCE FREE AND CORROSION RESISTANT.
 - SHALL BE PACKAGED AS PER L-COM SPEC PKG-00070

REGULATORY COMPLIANCE:
CE2011/65/EU(RoHS DIRECTIVE)

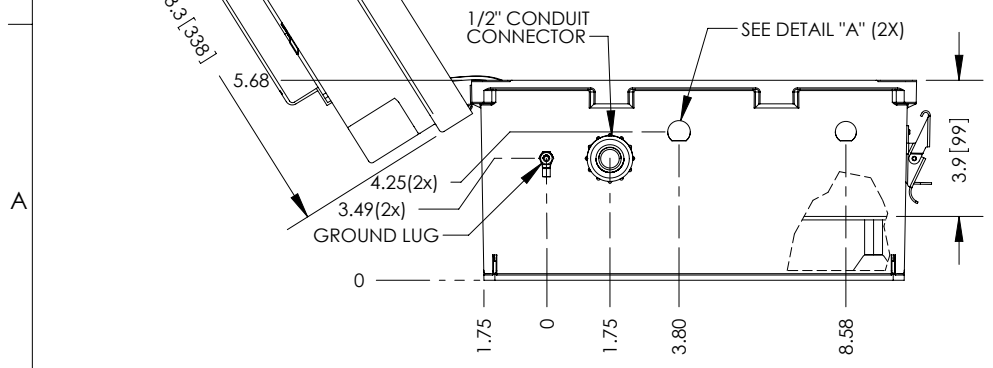
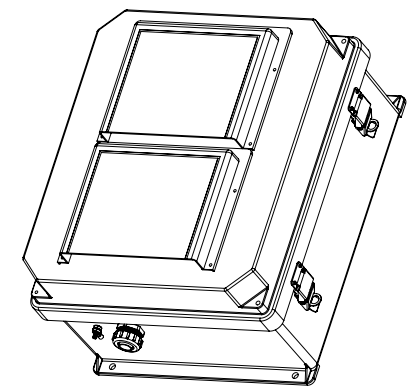
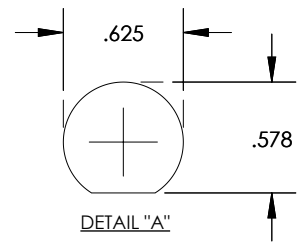
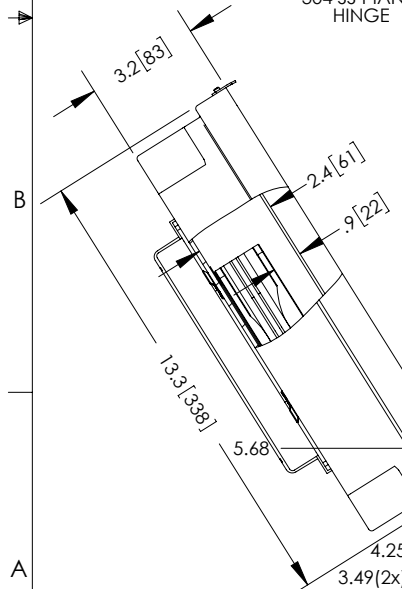

UNLESS OTHERWISE SPECIFIED, DIMENSIONS ARE IN INCHES [mm] DIMENSIONAL TOLERANCES: .X = ±.1 [2.54] .XX = ±.01 [2.5] .XXX = ±.005 [1.3] ANGULAR TOLERANCES: ALL = ± 1°	APPROVALS	DATE	 50 HIGH STREET NORTH ANDOVER, MA 01845
	DRAWN BY BPUCHASKI	04/04/2013	
	CHECKED BY P.PSEA	04/04/2013	
	APPROVED BY P.PSEA	04/04/2013	
PROJECTION	CONFIGURATION DETAILS OF UNDIMENSIONED FEATURES MAY VARY	CATEGORY ENCLOSURES	
	COLOR VARIATIONS MAY OCCUR	PRODUCT DESCRIPTION NEMA Enclosure 14 X 12 X 7 Weatherproof 120VAC w/Fan Solid State Controller-UL Approved	
SCALE: NONE	FSCM NO. A 43321	DWG. NO. NB141207-10FS-UL	REV. B
CAD FILE: NB141207-10FS-ULSLDRW		SHEET 1 OF 1	