

THE INFORMATION CONTAINED IN THIS DRAWING IS THE SOLE PROPERTY OF L-COM, INC. ANY REPRODUCTION IN PART OR WHOLE WITHOUT THE WRITTEN PERMISSION OF L-COM, INC. IS PROHIBITED.

REVISIONS			
REV	DESCRIPTION	DATE	APPROVED
A	INITIAL RELEASE	8/19/10	D.GRIFFIN
B	ECN 5463: ADDED PANEL CUTOUT	4/26/11	D. CASTRO

WIRE MAP	
DB9	TERMINAL BLOCK
1	1
2	2
3	3
4	4
5	5
6	6
7	7
8	8
9	9
GND	SHL

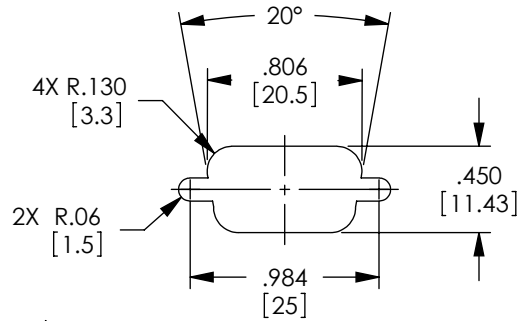
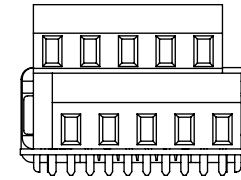
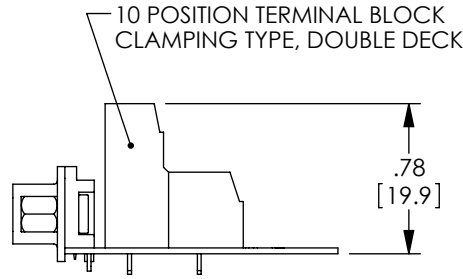
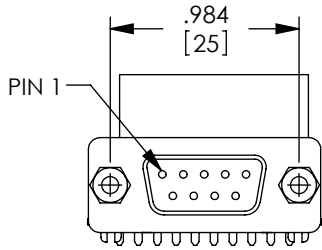
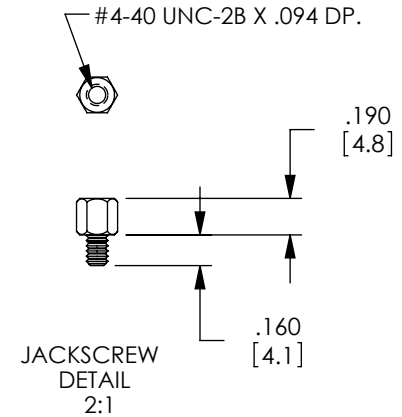
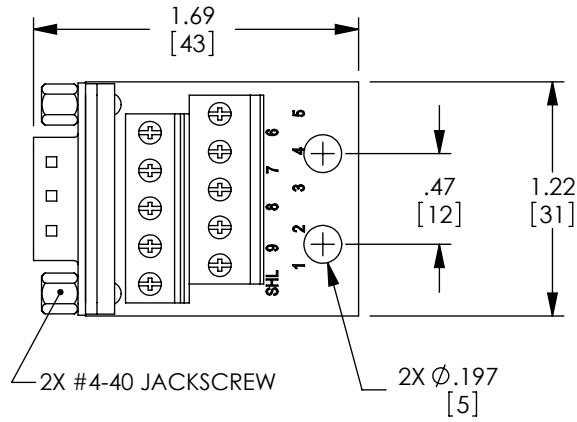

B RECOMMENDED PANEL OPENING
 (MAX PANEL THICKNESS: 0.06")

- NOTES:**
- VOLTAGE RATING: 1000V AC & 500V DC.
 - COMPONENT SHALL BE TESTED FOR CONTINUITY.
 - COMPONENT SHALL BE INDIVIDUALLY PACKAGED IN ACCORDANCE WITH L-COM SPEC. PS-0031.

RoHS Compliant ✓

UNLESS OTHERWISE SPECIFIED, DIMENSIONS ARE IN INCHES [mm] OVERALL CABLE LENGTH TOLERANCE: ≤12 [305] = +1 [25] / -0 >12 [305] ≤60 [1524] = +2 [51] / -0 >60 [1524] ≤120 [3048] = +4 [102] / -0 >120 [3048] ≤300 [7620] = +6 [152] / -0 >300 [7620] = +3% / -0%	APPROVALS	DATE	45 BEECHWOOD DRIVE NORTH ANDOVER, MA 01845
	DRAWN BY D. CASTRO	8/18/10	
ALL OTHER DIMENSIONAL TOLERANCES: .X = ±.2 .XX = ±.02 .XXX = ±.005	CHECKED BY D. PARHAM	8/18/10	PRODUCT DESCRIPTION CONN, DB9M FIELD TERMINATION
PROJECTION 	APPROVED BY S. SMITH	8/18/10	