

THE INFORMATION CONTAINED IN THIS DRAWING IS THE SOLE PROPERTY OF L-COM, INC. ANY REPRODUCTION IN PART OR WHOLE WITHOUT THE WRITTEN PERMISSION OF L-COM, INC. IS PROHIBITED.

REVISION					
ZONE	REV	DESCRIPTION	DATE	CHANGED BY	APPROVED
	A	INITIAL RELEASE	05/25/2023	DFRISIELLO	GUTTADAURO

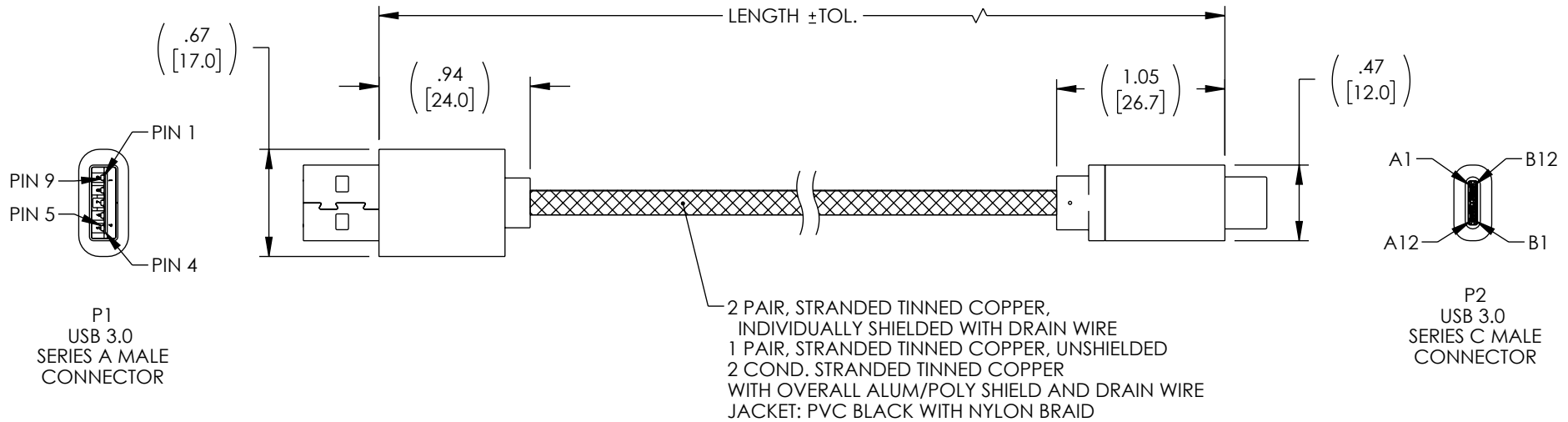

PIN Assignment

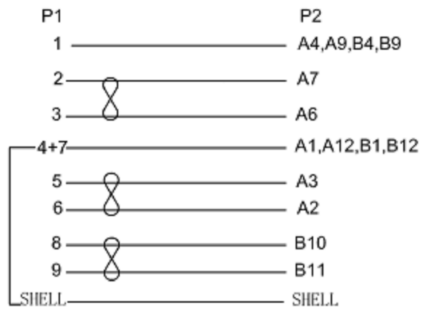

ITEM NUMBER	LENGTH, IN [mm]	TOLERANCE, IN [mm]
CAU3AC-MF-05M	19.69 [500.0]	±1.18 [30.0]
CAU3AC-MF-1M	39.37 [1000.0]	±1.18 [30.0]
CAU3AC-MF-3M	118.11 [3000.0]	±1.18 [30.0]

NOTES:

PASS: 5Gbps/2A 5V TEST

- CABLE ASSEMBLY SHALL BE TESTED FOR CONTINUITY.
- CABLE ASSEMBLY SHALL BE INDIVIDUALLY PACKAGED.

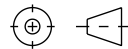
UNLESS OTHERWISE SPECIFIED, DIMENSIONS ARE IN INCHES [mm]	APPROVALS	DATE	 50 High Street, West Mill, North Andover, MA 01845 USA. Phone: 1.800.341.5266 1.978.682.6936
	OVERALL CABLE LENGTH TOLERANCE: ≤12 [305] = +1 [25] / -0 >12 [305] ≤60 [1524] = +2 [51] / -0 >60 [1524] ≤120 [3048] = +4 [102] / -0 >120 [3048] ≤300 [7620] = +6 [152] / -0 >300 [7620] = +5% / -0	DRAWN BY DFRISIELLO	
ALL OTHER DIMENSIONAL TOLERANCES: .X = ±.2 [5] FRACTIONS ± 1/32 .XX = ±.02 [5] ANGLES ± 1° .XXX = ±.005 [13]	CHECKED BY RCARLESCO	05/16/2023	CATEGORY USB 3.0
	APPROVED BY GUTTADAURO	05/16/2023	PRODUCT DESCRIPTION USB 3.0, AM/CM, Alum Shell, 5V/2A 5Gbps, Black Nylon Braid
THIRD-ANGLE PROJECTION 	CONFIGURATION DETAILS OF UNDIMENSIONED FEATURES MAY VARY	COLOR VARIATIONS MAY OCCUR	SIZE A
			CAGE CODE 43321
			ITEM NO. CAU3AC-MM
			REV. A
			SCALE: NONE
			CAD FILE: CAU3AC-MM.SLDDRW
			SHEET 1 OF 1