

6

5

4

3

2

1

REVISION					
ZONE	REV	DESCRIPTION	DATE	CHANGED BY	APPROVED
	D	ECO-15673	03/26/2026	HBAKKE	DWANG

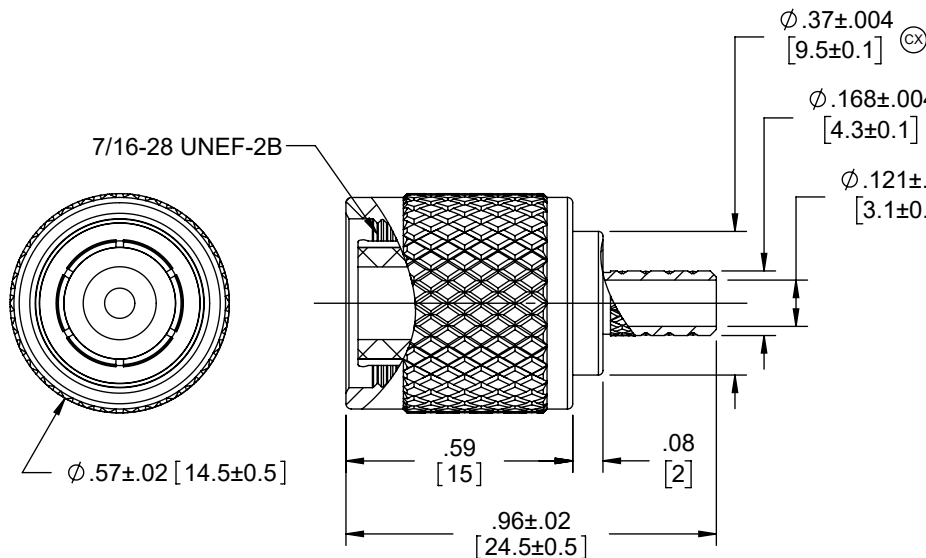

BODY; SNAP RING; O-RING SEALING;
INSULATOR KITS

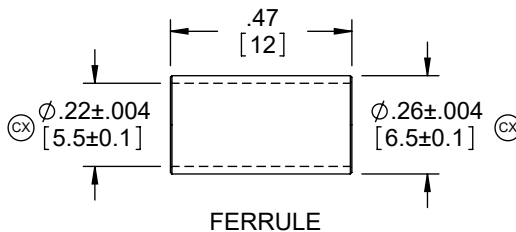
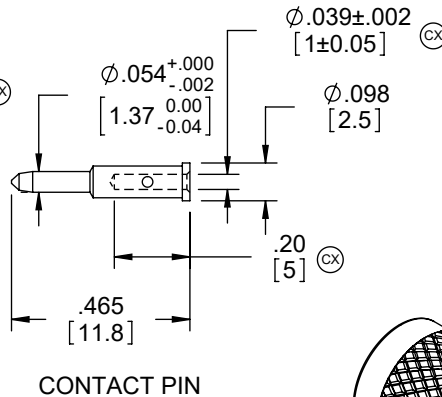

RECOMMENDED HEX TOOLING
CRIMP DIMENSION

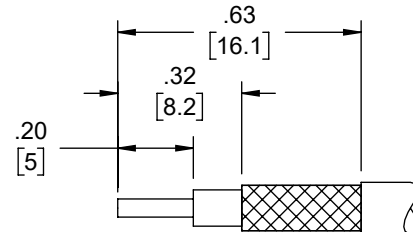
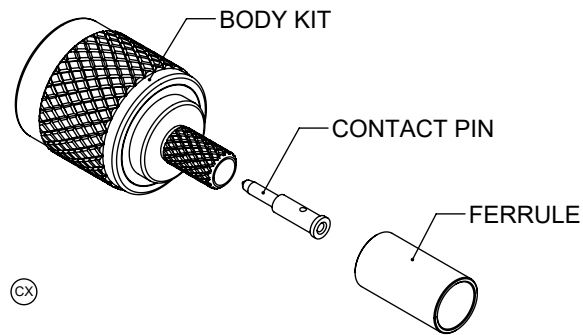

NOTES:

- MATERIAL:
BODY, FERRULE: BRASS; NICKEL PLATED
CENTER PIN: BRASS, 1~3 μ in GOLD OVER NICKEL PLATED
SNAP RING: PHOSPHOR BRONZE
INSULATOR: PTFE; COLOR: WHITE
O-RING SEALING: SILASTIC
- ELECTRICAL:
IMPEDANCE: 50 Ω
VSWR: 1.5 MAX @ DC ~6 GHz
CONTACT RESISTANCE: 2.5 m Ω MAX (CENTER PIN)
INSULATION RESISTANCE: 5000 M Ω MIN
DIELECTRIC WITHSTANDING VOLTAGE: 1500 V r.m.s
- MECHANICAL:
DURABILITY: 500 CYCLES MIN
CENTER CONTACT RETENTION AXIAL FORCE: 26.7 N MIN
- (CX) REPRESENTS CRITICAL DIMENSION.
- INTERFACE DIMENSION AND PERFORMANCE REQUIRED
IAW MIL-STD-348 & MIL-PRF-39012E.

REGULATORY COMPLIANCE:
RoHS DIRECTIVE (MOST RECENT RELEASED VERSION).

THE INFORMATION CONTAINED IN THIS DRAWING IS THE SOLE PROPERTY OF INFINITE ELECTRONICS, INC. ANY REPRODUCTION IN PART OR WHOLE WITHOUT THE WRITTEN PERMISSION OF INFINITE ELECTRONICS, INC. IS PROHIBITED. THESE COMMODITIES, TECHNOLOGY OR SOFTWARE WERE EXPORTED FROM THE UNITED STATES IN ACCORDANCE WITH THE EXPORT ADMINISTRATION REGULATIONS. DIVERSION CONTRARY TO U.S. LAW PROHIBITED.

UNLESS OTHERWISE SPECIFIED LEADING DIMENSIONS ARE INCHES DIMENSIONS IN [] ARE MILLIMETERS TOLERANCES: .X = ±.2 [5] FRACTIONS ± 1/32 .XX = ±.02 [0.5] ANGLES ± 1° .XXX = ±.005 [0.13]	 an INFINIT@ brand Website: www.L-com.com Phone: 1.800.341.5266 1.978.682.6936		 INTERPRET ALL DIMENSIONS AND TOLERANCES PER ASME Y14.5	
			SCALE	SHEET
CABLE LENGTH TOLERANCES: ≤12 [305] = +1 [25] / -0 >12 [305] ≤ 60 [1524] = +2 [51] / -0 >60 [1524] ≤ 120 [3048] = +4 [102] / -0 >120 [3048] ≤ 300 [7620] = +6 [152] / -0 >300 [7620] = +5% / -0 CABLE LENGTH TOL IAW IPC A-620	DESCRIPTION		NONE	1 OF 1
ALL DIMENSIONS ARE FOR REFERENCE ONLY AND SUBJECT TO CHANGE WITHOUT NOTICE. UN-DIMENSIONED (NON-CRITICAL) FEATURES MAY VARY IN SIZE AND LOCATION COLORS MAY VARY	SIZE	CAGE CODE	DRAWN BY	ITEM NO.
	A	43321	BZHANG	BAC545
				REV
				D

6

5

4

3

2

1