



## OUTDOOR INSTALLATION WARNING

### IMPORTANT SAFETY PRECAUTIONS:

**LIVES MAY BE AT RISK!** Carefully observe these instructions and any special instructions that are included with the equipment you are installing.

**IMPORTANT:** Look over the site before beginning any installation, and anticipate possible hazards, especially these:

**CONTACTING POWER LINES CAN BE LETHAL.** Make sure no power lines are anywhere where possible contact can be made. Antennas, masts, towers, guy wires or cables may lean or fall and contact these lines. People may be injured or killed if they are touching or holding any part of equipment when it contacts electric lines. Make sure there is NO possibility that equipment or personnel can come in contact directly or indirectly with power lines.

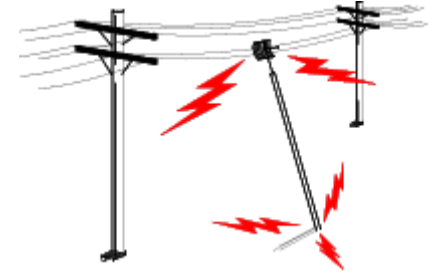

Assume all overhead lines are power lines.

The horizontal distance from a tower, mast or antenna to the nearest power line should be at least twice the total length of the mast/antenna combination. This will ensure that the mast will not contact power if it falls either during installation or later.

### TO AVOID FALLING, USE SAFE PROCEDURES WHEN WORKING AT HEIGHTS ABOVE GROUND.

- Select equipment locations that will allow safe, simple equipment installation.
- Don't work alone. A friend or co-worker can save your life if an accident happens.
- Use approved non-conducting ladders and other safety equipment. Make sure all equipment is in good repair.
- If a tower or mast begins falling, don't attempt to catch it. Stand back and let it fall.
- If anything such as a wire or mast does come in contact with a power line, **DON'T TOUCH IT OR ATTEMPT TO MOVE IT.** Instead, save your life by calling the power company.
- Don't attempt to erect antennas or towers on windy days.

**MAKE SURE ALL TOWERS AND MASTS ARE SECURELY GROUNDED, AND ELECTRICAL CABLES CONNECTED TO ANTENNAS HAVE LIGHTNING ARRESTORS.** This will help prevent fire damage or human injury in case of lightning, static build-up, or short circuit within equipment connected to the antenna.

- The base of the antenna mast or tower must be connected directly to the building protective ground or to one or more approved grounding rods, using 1 OAWG ground wire and corrosion-resistant connectors.
- Refer to the National Electrical Code for grounding details.
- Lightning arrestors for antenna feed coaxial cables are available from HyperLink Technologies, Inc.

### IF A PERSON COMES IN CONTACT WITH ELECTRICAL POWER, AND CANNOT MOVE:

- **DON'T TOUCH THAT PERSON, OR YOU MAY BE ELECTROCUTED.**
- Use a non-conductive dry board, stick or rope to push or drag them so they no longer are in contact with electrical power.
- Once they are no longer contacting electrical power, administer CPR if you are certified, and make sure that emergency medical aid has been requested.

Copyright © This drawing is property of L-com Global Connectivity. All rights reserved.

## HA2401RTG Series Amplifier User Manual

For Model Numbers: HA2401RTG-100/250/500/1000

**FCC PART 15 NOTICE: THIS AMPLIFIER CAN BE USED ONLY IN A SYSTEM WHICH IT HAS OBTAINED AUTHORIZATION. THE AUTHORIZED SYSTEM BY FCC IDENTIFIER IS: MYF-XI-325**

This manual covers the basic mounting and installation instructions for the amplifier unit only. Please refer to the **WLKIT-GX-GXI Series Kits User Manual** or the **PC Card User Manual** for PC card and software installation instructions as well as a complete list of certified antennas and system components.

### Connecting the Amplifier

Amplifier connections are clearly labeled on the amplifier unit as shown below.

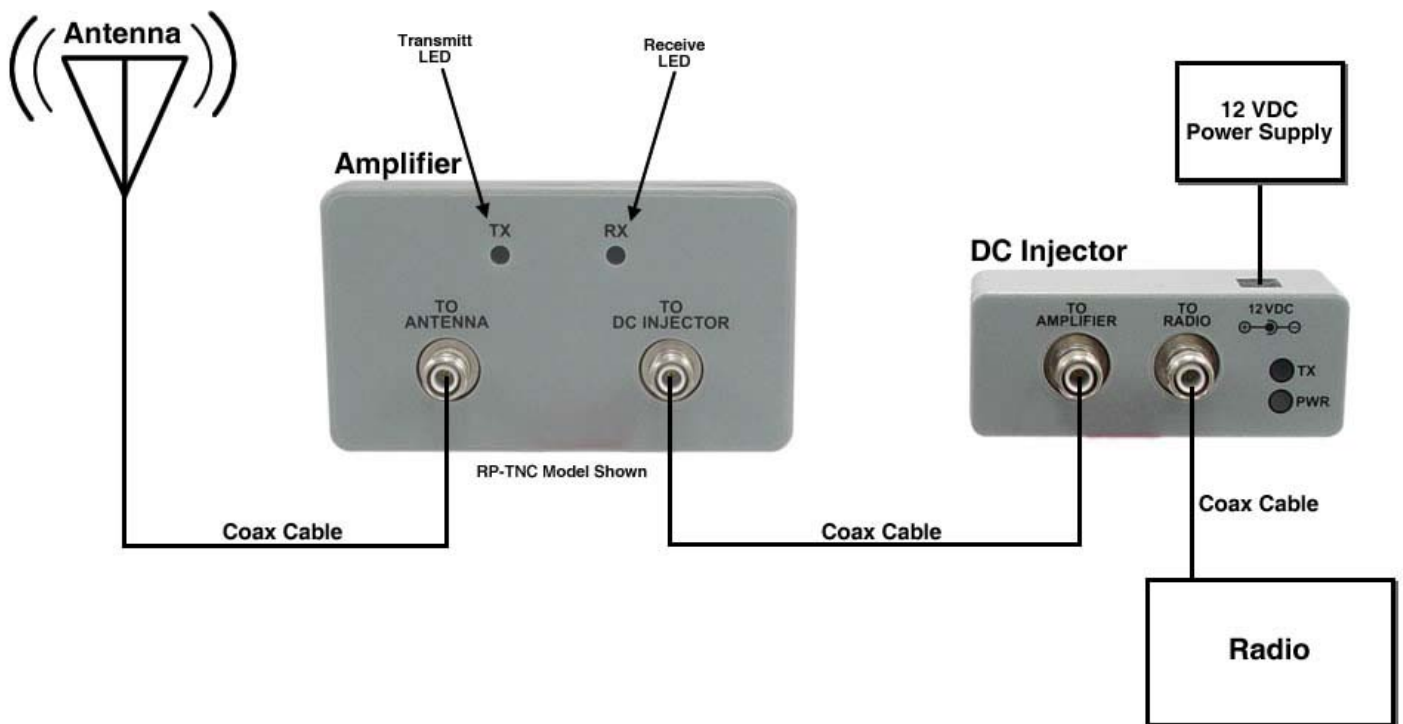

1. Connect the Antenna to the Amplifier output labeled "**ANTENNA**".
2. Connect the DC Injector output labeled "**TO AMPLIFIER**" to the Amplifier input labeled "**TO DC INJECTOR**".
3. Connect the Radio to the DC Injector input labeled "**TO RADIO**" using the pigtail cable.
4. Plug the AC Adapter into the DC Injectors DC power jack and wall outlet.

Copyright © This drawing is property of L-com Global Connectivity. All rights reserved.

## Mounting the Amplifier

The HyperAmp HA2401RTG Series Amplifiers are designed for outdoor mounting, close to the antenna. Installed indoors near the radio, the DC Injector provides power to the amplifier via the coax cable. The following shows how to mount the amplifier:

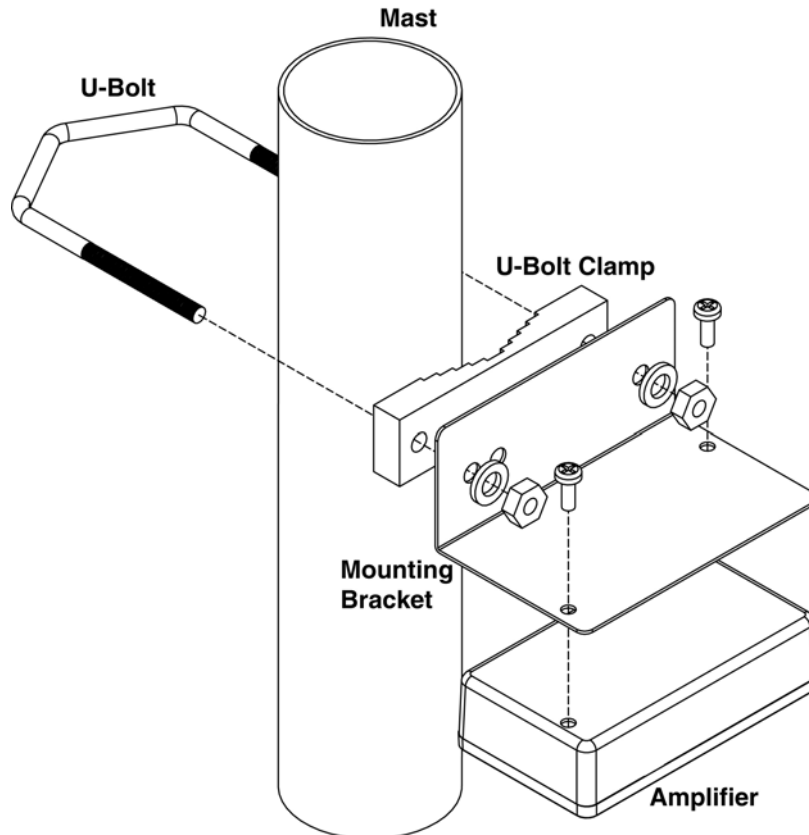

1. Attach the included L-Bracket to the amplifier as shown using two Pan Head screws. Note: the tapped holes on the rear of the amplifier do not require sealing.
2. Mount the amplifier-bracket assembly to the mast as shown using the U-Bolt and included hardware. To prevent water from leaking into the amplifier via the RF connectors, it is recommended that the amplifier be mounted with the RF connectors facing down as shown.
3. Attach the required cables to the amplifier.

Copyright © This drawing is property of L-com Global Connectivity. All rights reserved.

## Operation of Amplifier LEDs

All HyperGain amplifiers have two LEDs visible on the enclosure.

The LED marked **TX** indicates that the amplifier is transmitting a signal. This LED will flash during such operation.

The LED marked **RX** indicates that the amplifier is receiving a signal. This LED will flash during such operation.

When the amplifier is transmitting and receiving signals at the same time, both LEDs will flash.

\*Note: Some amplifier models have a **red** TX LED for extra visibility. A flashing red LED **does not** indicate a fault.

