

Premise Wiring Terms

Premise Wiring is the cabling, connectors and accessories that are used to connect LAN (Local Area Network) and phone equipment within a commercial building. Premise Wiring is standardized, this means that a governing body (in this case ANSI and TIA/EIA) set requirements regarding the minimum performance levels for products used as well as offer design and layout criteria that must be followed. The end result of a standard is that all the manufacturers are "on the same page" with regards to how they make their premise wiring products. Also, all cable installers should follow the same rules making it easier to troubleshoot and expand the wiring in the future.

To explain all of the details that pertain to premise wiring in one page is nothing short of impossible. Nonetheless, this page can be used as a primer for those who wish to understand things a little further. The first place to start is with common terms:

Backbone Wiring: The cabling used between telecommunication closets, entrance facilities, equipment rooms, or buildings.

Category 5E/6: The standard unshielded twisted pair cabling used for LAN drops.

Conduit: Circular raceway that cable is run inside. Conduit requirements are specified under appropriate electrical code.

Cross Connect: The connection method used between permanent cabling (inside the walls) and equipment. A patch cord is often used as the connection means.

Demarcation Point: The point at which operational control changes (for example, where the phone company's responsibility ends and the building owner's begins).

Drop: Slang term used for each cabling span pulled from a telecommunication closet.

Equipment Room: The space dedicated to telecommunications equipment.

Horizontal Wiring: The span of cabling and connectors between the wiring closet and each drop. It is called horizontal because this type of wiring does not go up or down any floors of a building.

Insulation Displacement Contact (IDC): A means of terminating wires without the need of stripping down to the bare wire.

Jumper: Single twisted pairs used for cross connecting between 66, 110, or Krone blocks.

Modular Jack: The female connector used at the end of each horizontal cabling drop. Usually Modular Jacks utilize a 6 or 8 contact modular plug (on the patching side) and a 110, Krone, or other Insulation Displacement connection method (on the permanent horizontal wiring side).

Modular Plug: The male connector usually found at the end of a patch cord.

Patch Cord: A cable assembly with modular plugs on each end. Used for patching equipment to the patch panel in the equipment room and also used to connect to phones and computers at the drop.

Patch Panel: The common cross connect method used inside an equipment room. Typical Patch Panels utilize 110 or Krone connectors (on the rear) to connect to the horizontal cabling and modular jacks on the front to connect to equipment via patch cords.

Star Topology: The topology where wiring stems from one central point.

Telecommunications Closet: Enclosed space for containing telecommunications equipment, cable terminations and cross connects.

Work Area: Building space where occupants utilize telecommunications equipment.

Typical LAN Premise Wiring

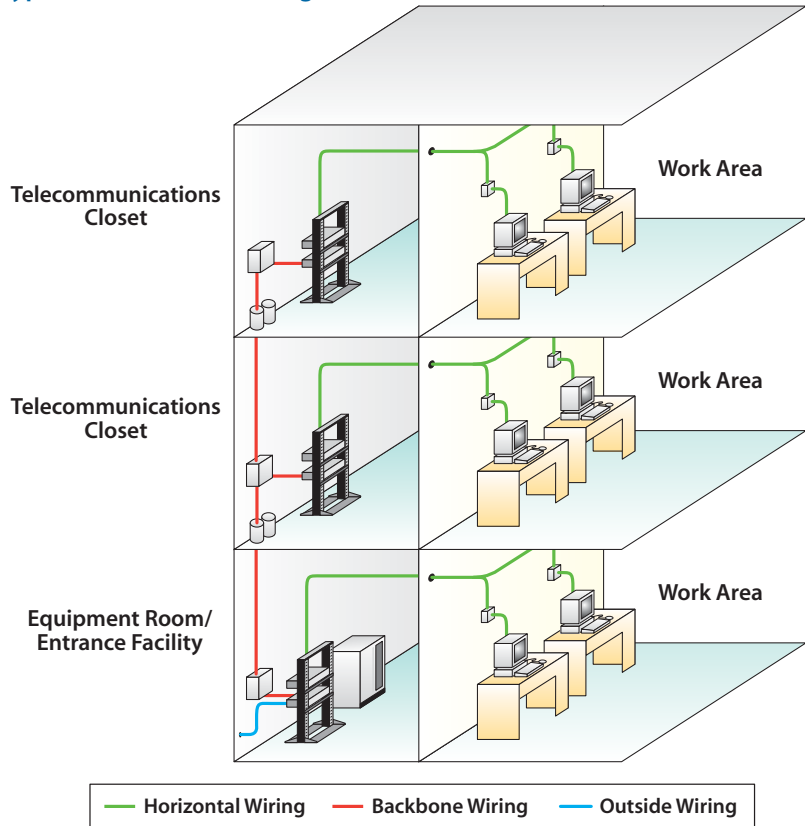

Wiring Notes:

1. Category 5E/6 unshielded twisted pair is the norm. Use 4 pair solid conductor inside the walls, 4 pair stranded for patch cords. Plenum rated cabling may be necessary depending upon fire codes in your area.
2. Maximum distance for a horizontal run is 90m plus an additional 10m for patching.
3. Fiber is the common choice for backbone wiring. It is also recommended for horizontal runs over 100m.

Common Wiring Standards for Data Communications

There are two common wiring standards for LAN wiring. When buying components such as jacks or patch panels, be sure to specify if EIA568A or EIA568B is needed.

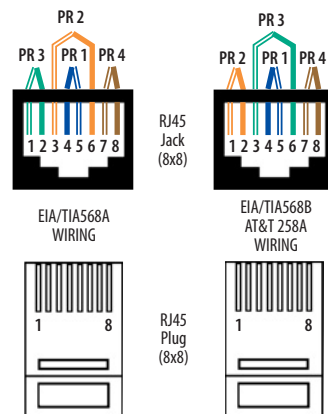

Typical Telecommunications Closet

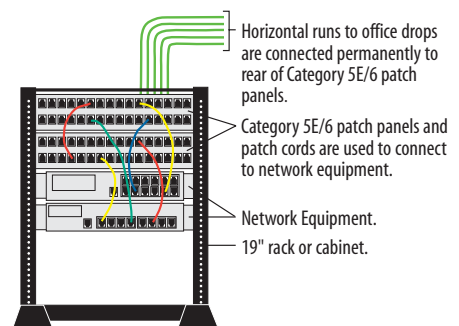

Typical Office Drop

