

MATERIALS	
BODY	NICKEL PLATED BRASS
CONTACT	GOLD PLATED BRASS
INSULATOR	PTFE

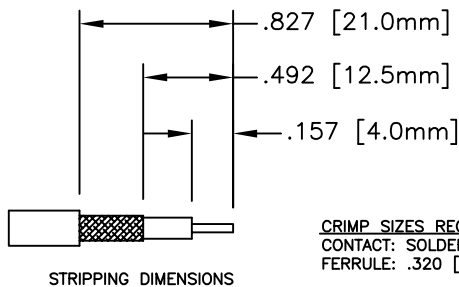
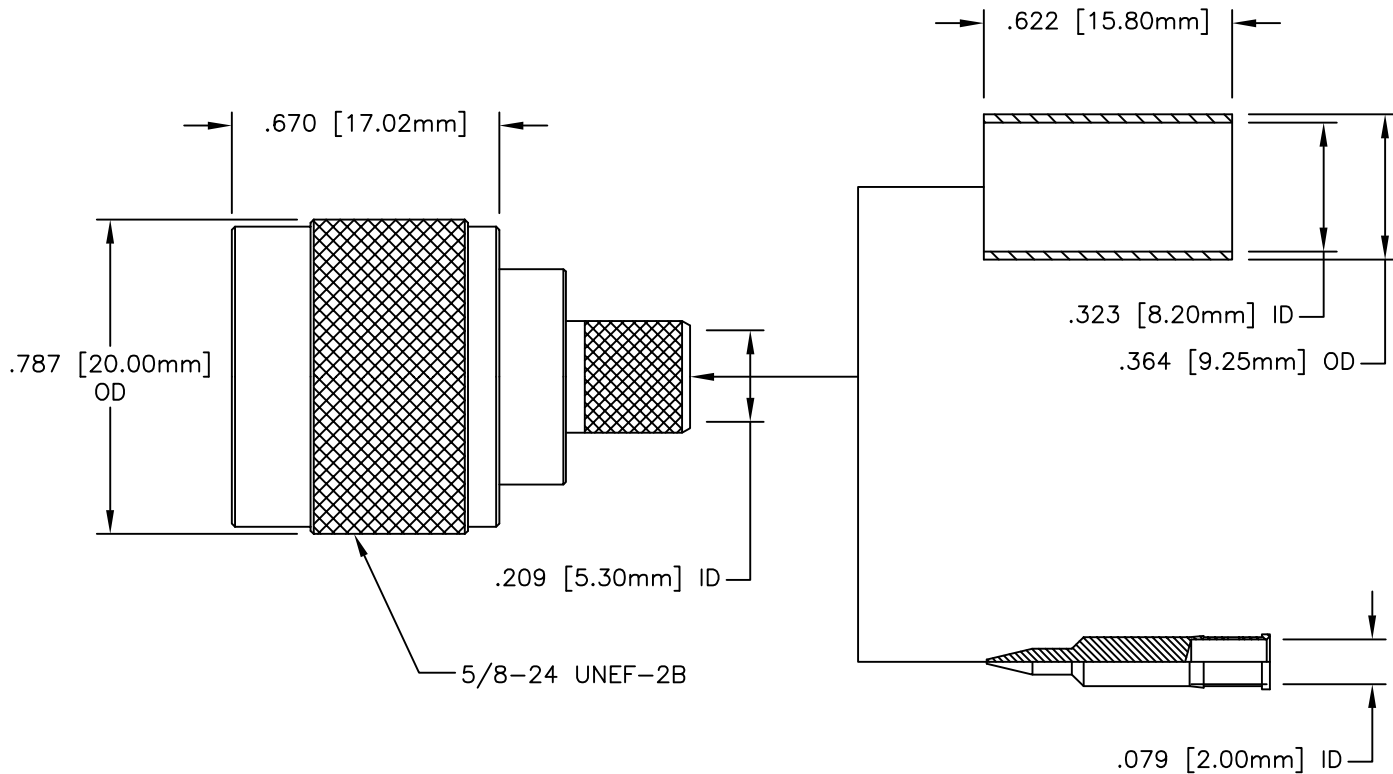

CRIMP SIZES REQUIRED
 CONTACT: SOLDER
 FERRULE: .320 [8.1] HEX CRIMP TOOL

- NOTES:
 1. UNLESS OTHERWISE SPECIFIED ALL DIMENSIONS ARE NOMINAL.
 2. ALL SPECIFICATIONS ARE SUBJECT TO CHANGE WITHOUT NOTICE AT ANY TIME.

				SIZE	TITLE:			
				A	N-MALE CRIMP CONNECTOR FOR 300-SERIES CABLE			
B	-	11/23/07	Updated Dwg					
REV	ECN No.	DATE	DESCRIPTION	DRAWN BY	K.Burgner	11/23/07	DRAWING No.	REV
				ORIGINATOR	K.Burgner	11/23/07	ANM-1304	B
				APPROVAL	K.Burgner	11/23/07	PART No.	ANM-1304
				SCALE 3:1	SHEET 1/1	MATERIAL ---	FILE No.	ANM-1304



Website: www.L-com.com
 Tel: 1-800-343-1455
 Copyright © 2009 L-com, Inc.
 All rights reserved.